

☎ 1-800-323-0796 USA
☎ 1-800-268-5392 Canada

ADAMS

Installation and Operation Manual

Safety Light Curtain for Elevator Door Protection Gatekeeper® EZ

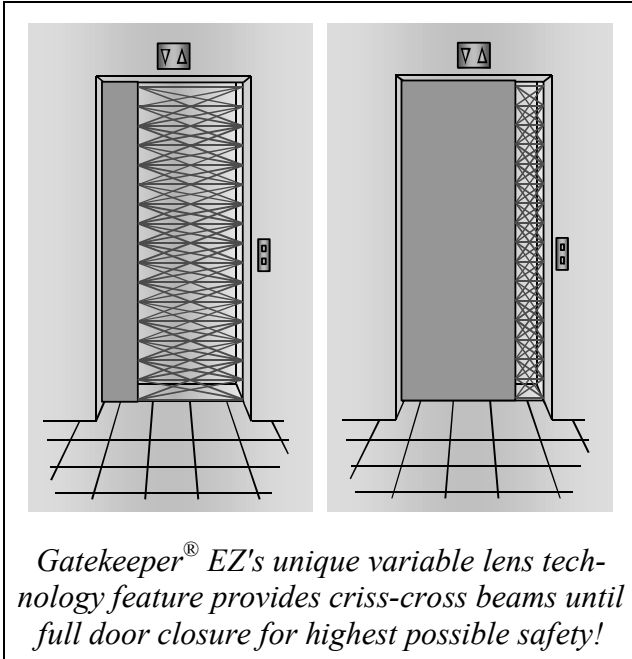

manufactured under ISO 9001: 2000

IMPORTANT NOTE

**FOLLOW THE INSTRUCTIONS GIVEN IN THIS MANUAL CAREFULLY.
FAILURE TO DO SO MAY CAUSE CUSTOMER COMPLAINTS AND SERIOUS
CALL BACKS.
KEEP INSTRUCTION MANUAL ON SITE.**

IMPORTANT NOTICE

WHEN THE GATEKEEPER® EZ LIGHT CURTAIN IS USED AS A REPLACEMENT FOR MECHANICAL SAFETY EDGES, IT IS THE RESPONSIBILITY OF THE INSTALLER TO ENSURE THAT ON COMPLETION, THE INSTALLATION COMPLIES WITH ALL THE RELEVANT STATE CODES, LOCAL CODES AND REGULATIONS THAT PERTAIN TO INFRARED AND PHOTOELECTRIC DOOR PROTECTION DEVICES!

IN CANADA, PARTICULAR ATTENTION SHOULD BE GIVEN TO CLAUSES 2.13.5.1 AND 2.13.5.2 CAN/CSA-B44-B89!

GATEKEEPER® EZ MUST BE INSTALLED ONLY BY AUTHORIZED AND FULLY TRAINED PERSONNEL.

PLEASE TAKE NOTE THAT OBJECTS THINNER THAN THE SENSOR SPACING MAY NOT BE DETECTED.

DO NOT USE THIS PRODUCT FOR THE PROTECTION OF DANGEROUS MACHINERY OR IN EXPLOSIVE ATMOSPHERES OR RADIOACTIVE ENVIRONMENTS! USE ONLY SPECIFIC AND APPROVED TYPES OF SAFETY DEVICES FOR SUCH APPLICATIONS, OTHERWISE SERIOUS INJURY OR DEATH OF PERSONNEL MAY OCCUR!

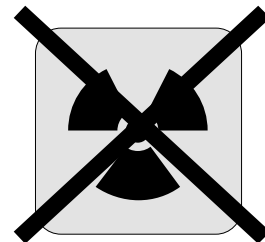
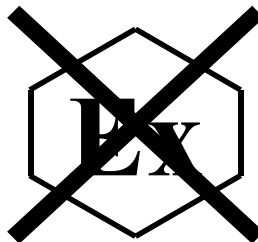
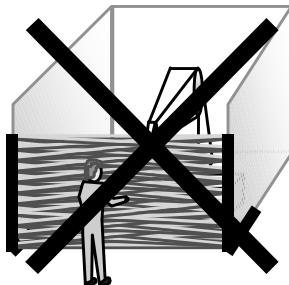

1. Content

1. Content	3
2. Introduction	4
3. Features of Gatekeeper® EZ	4
4. Installation	5
4.1. Switch main power off and mark clearly that this elevator is out of service.....	5
4.2. Mount the emitter and the receiver	5
4.3. Guide the cables properly to prevent damage	7
4.4. Connect the emitter and the receiver cables	7
4.5. Power-up and test for proper function	7
5. Trouble shooting	8
6. Maintenance	8
7. Disposal	8
8. Technical Data	9
8.1. Certificate of Compliance	9
9. Dimensions	10
10. Part Numbers	11
10.1. Complete units	11
10.2. Spare parts and accessories.....	11

2. Introduction

The infrared light curtain Gatekeeper® EZ consists of an emitter and a receiver edge, both of which have a built-in controller. These two active parts are electrically connected directly to the door drive unit of the elevator and mechanically mounted either to the car door wings and / or to the slam post. There are various types of optional mounting kits available from ADAMS. These kits are optimized to a specific door drive or car type.

The emitter and the receiver edge build up a grid of infrared beams, which cover the door entrance to a height of 1,800 mm (6 feet). The number of beams covering the entrance area is dependent on the model in use. The number after the product name 'Gatekeeper® EZ' indicates the maximum number of active beams. The higher the number, the more beams are active and therefore smaller objects can be detected. However, product cost increases with the number of beams.

The emitter and the receiver require a power supply of between 10 and 30 VDC. The output of the receiver is a push / pull (PNP / NPN) stage, which is compatible with loads connected to positive as well as to negative power. The output signal of the receiver can be inverted by connecting the white input selector wire either to positive or to negative power. No electrical connection between the emitter and the receiver is necessary because Gatekeeper® EZ uses an optical synchronization principle.

To increase the lifetime of the electronic components, especially the infrared emitters, the control unit continuously controls LED light emission power according to the distance between the emitter and the receiver. When the doors are closed, the emitting power is almost zero. This function also prevents optical bypassing at the car door sill. This makes Gatekeeper® EZ the most reliable device on the market.

If permanent blocking of a sensor element occurs, Gatekeeper® EZ recognizes this condition as a defective or blocked element. After 45 seconds, this particular sensor element is blanked and is no longer active. This function allows operation of the device even with partial damage or blockage due to vandalism. Up to two non-adjacent sensor elements in the emitter or receiver edges can be blanked out.

Note: This function is not available in the USA or in Canada.

If a power supply of 10 to 30 VDC is not available, a state-of-the-art Power Supply (including Relay contact) available from ADAMS may be used. This product is especially useful in modernization applications where the supply voltage is not standardized or known.



A specific feature of Gatekeeper® EZ is the reduction of light emission power in the infrared LED's. This unique feature was invented and patented by ADAMS in 1990 and increases LED lifetime almost to infinity. However, this feature works properly only if the sequence of closing and opening the door is correct. When the doors are closing, the light emission power of the LED's decreases. Once the doors are closed, Gatekeeper® EZ turns off the angled beams. Only straight beams are active until the doors reopen by more than approximately 50 cm. This functionality has to be considered when Gatekeeper® EZ is under test in a laboratory where the closing and opening cycle are not followed.

3. Features of Gatekeeper® EZ

- Criss-cross beams **until full closure** for best-in-class detection capability
- Designed lifetime of more than 20 years due to
 - gold plated contacts and pcb's
 - power reduced light output during door close cycle
 - special cable that withstands more than 20 million door openings (if properly installed)
- Robust and extremely compact design
- Plug'n-play edges with integrated controller
- Suitable for side or center opening doors
- Suitable for metal or glass doors
- Suitable for dynamic or static installation
- Blanking of up to two defective sensor elements (not adjacent) after 45 seconds (**this function is not available in the USA or in Canada**)
- Mechanically compatible to Gatekeeper®

4. Installation

The Installation should be done in the following sequence:

4.1. Switch main power off and mark clearly that this elevator is out of service

For your own safety, turn the power off before you start working on the elevator! Clearly mark that this elevator is out of service.

4.2. Mount the emitter and the receiver



The emitter and the receiver edge can be mounted either to the door wings, to the door wing and the slam post, or to a frame that is attached to the car.

! Please note that objects smaller than the sensor spacing may not be detected! In the USA and Canada, Gatekeeper® EZ (type 79 beams) shall be used only if the emitter and receiver edge are each set back from the leading edge of the door and/or slam post by at least one sixth of the full door opening.

! The black plastic profile with the curved surface is the front of the edge. This side has to "look" at its companion piece, which is mounted on the opposite cab door or slam post.

! Please note that the receiver (the one with the blue connector) can be sensitive to "foreign" light. No other source of external light, including the emitter of any other light barrier system, should be directed towards the receiver edge. Although Gatekeeper® EZ is very tolerant of bright sunlight, it is better to mount the receiver edge so that no sun light shines directly into the curved front area of the receiver lens. It is similar to human eyesight: while you may have visibility even if looking directly into the sun, it is harder to see clearly. Therefore, it is always better to have the sun at your back!

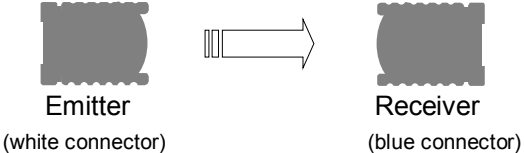
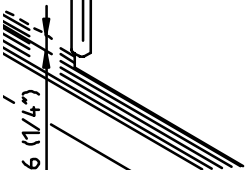
Please observe the following mounting guidelines:

	<p>Never scratch the curved front surface because this is the lens that forms the light path! At the installation site, leave the edges in the protective cardboard box / protective hose for as long as possible!</p>
 <p>Emitter (white connector)</p> <p>Receiver (blue connector)</p>	<p>The curved surface of the emitter and the receiver should point to each other face-to-face!</p> <p>Align the optical axis of the emitter and the receiver as close as possible in order to achieve best performance ($\pm 5^\circ$)!</p>
	<p>The recommended distance between the door sill and the bottom of the sensors is 6 mm ($\frac{1}{4}$"). A greater distance reduces safety due to an unprotected area right above the sill!</p>
	<p>Do not bend or twist the edges!¹</p> <p>Oil may damage the cable. Contamination must therefore be avoided at all times!</p>

¹ Depending of the environment temperature, the Gatekeeper EZ® edges may appear bowed. This is a natural phenomenon due to differing expansion coefficients of the plastic and aluminum components of the edges. Do not try to bend or twist the edges straight.

	<p>Avoid direct sunlight that could interfere with the receiver edge!</p> <p>Avoid external light from other infrared light sources like photo eyes or light barriers!</p>
	<p>! In the USA and Canada, the Gatekeeper® EZ (type 79 beams) can be used only if the emitter and the receiver edge are set back from the leading edge of the door and / or from the slam post by at least one sixth of the full door opening.</p>
	<p>! Screw the green / yellow wire to the grounded door panel to avoid electromagnetic noise pickup. Hence, the door panels shall be grounded.</p> <p>! Fix the connector with a cable tie wrap to the door panel or mounting profile.</p>
	<p>The total length of the edges is 2,100 mm (7 feet). In case this is too long, the edges can be cut with a common metal saw. To do so, please comply with the following procedure in order to avoid damaging the device:</p> <p>1. Cut the profile (Figure A)</p> <ol style="list-style-type: none"> ①+② Remove the top fixing part and the aluminum cover ③ Bend the cable away from the area being cut ④ Cut the plastic profile and the aluminum cover with a metal saw <p>2. Re-assemble the profile (Figure B)</p> <ol style="list-style-type: none"> ① Bend the cable upwards (towards the lenses) ② Attach the top fixing part from the back and assure to mount it in the right direction ③ Snap on the aluminum cover

4.3. Guide the cables properly to prevent damage

Guide the cables properly using appropriate mounting material, e.g. cable protection tubes, neoprene cable ties and cable guide wires (depending on the type of mounting kit used).



If the cables are not properly fixed and guided, their lifetime could be reduced drastically. They can also be damaged due to possible swing and snag in the hoistway! Always follow the cable guide instructions carefully, which can be found in this installation and operation manual.

4.4. Connect the emitter and the receiver cables

Make sure that the power supply voltage available for Gatekeeper® EZ is between 10 and 30 Volts DC. The power supply has to provide at least 100 mA for proper operation.

Gatekeeper® EZ meets all standards for resistance to electromagnetic interference (EMI). However, it is prudent to guard against interference. Therefore, do not guide Gatekeeper® EZ connection cables close to cables carrying high voltage and/or high current. The Gatekeeper® EZ cables should also be mounted as far away as possible from the door drive motor or motor inverter (VVVF-drives) to avoid EMI problems.

<p>Emitter edge</p> <p>Receiver edge</p>	<p>Emitter brown: +10 – 30 VDC blue: GND (0V)</p> <p>Receiver brown: +10 – 30 VDC blue: GND (0V) black: Output white: Output Selector* (see below)</p>
<p>Fuse 0.5 A slow blow</p> <p>+10 – 30 VDC</p> <p>GND</p>	<p>Power should be provided on site with an over-current protecting fuse of max. 500 mA with "slow-blow" tripping characteristics.</p>
<p>*Output voltage:</p> <p>GND</p> <p>+10 – 30 V</p>	<p>Output Selector (white wire) connected to +10 – 30 VDC (brown wire)</p>
<p>*Output voltage:</p> <p>+10 – 30 V</p> <p>GND</p>	<p>Output Selector (white wire) connected to GND (blue wire)</p>

4.5. Power-up and test for proper function

Turn on power after Gatekeeper® EZ has been correctly installed. The green LED's in the white emitter and the blue receiver plug should turn on to indicate

that there is supply voltage available. The amber LED in the blue receiver plug is on, when one or more beams are interrupted. With no object and aligned edges, the amber LED is off.

5. Trouble shooting

If Gatekeeper® EZ does not operate as expected, observe the following trouble shooting guide step by step:

1. Check supply voltage both on emitter and receiver.
Are the green LED's in the emitter and receiver plug on? Is the supply voltage between 10 and 30 Volts DC? The ripple on the DC voltage should not exceed more than 10 % of the mean voltage.
2. If the output of the receiver (black wire) is high when the protected area is not obstructed, and in this case it should be low, connect the white wire of the receiver cable to ground (blue wire, refer to page 7: Output voltage)
3. If the output of the receiver (black wire) is low when the protected area is not obstructed, and in this case it should be high, connect the white wire of the receiver cable to positive power (brown wire, refer to page 7: Output voltage).
4. If the output signal of the receiver is not stable during the closing of the door, make sure that:
 - a. there is not excessive EMI-noise generated by the door drive or the door inverter or any other means that is disturbing the door edge. In such a case, move the cable of the receiver so that the distance to the noise source is as wide as possible. In addition, filter the noise of the source by using the optional Power Supply (including Relay contact) available from ADAMS.
 - b. there are no obstacles between the emitter and the receiver. Make sure that the door lock or any other obstacle does not enter the light path.
 - c. the edges are properly installed so that they cannot swing or vibrate and therefore lose line of sight between themselves.
 - d. the curved front surfaces of the edges are clean and not full of dust or dirt. Although Gatekeeper® EZ is very tolerant to this condition, its performance is much better when it is clean.
5. If the doors are closing even with an obstacle¹, there could be several reasons:
 - a. Output selector (white wire) not properly set (see steps 2 and 3 above)
 - b. Output not correctly wired to door operator
 - c. Faulty/defective system wiring or defective receiver edge²

¹ Due to the nature of door system designs, (which as complete systems are not fail safe), doors can close even with an obstacle present in extremely rare conditions. Therefore, there must be, by code, other safety means to prevent passengers from being hurt by the elevator doors. These dangerous situations should and can be detected by the elevator control, which should, in such a case, take the elevator out of service.

² This device (as well as all other door protection systems on the market) cannot – by its nature – provide absolute safety for elevator passengers passing through the doorway. It must not be used as the final fail safe

6. Maintenance

Although Gatekeeper® EZ does not need periodical maintenance, a functional check with every elevator maintenance check, or every 6 months, is strongly recommended. This periodic functional test should consist of the following:

- Test the reopening function over the whole door area. The door should reopen if an object is placed anywhere between the sill and up to 6 feet above the sill.
- Clean the front surface with a soft towel from dust or dirt. Especially when the door edges are installed before the construction of the building is finished (perhaps weekly during construction). To clean the surface with a towel, it must be either dry or slightly moist, but not wet.
- Confirm edges are fastened securely to the door wings and slam post.
- Confirm cables are routed properly as described in the appropriate mounting kit installation manuals.



Important notices:

Never use any solvents, cleaners or mechanically abrasive towels to clean the edge. The plastic lens can be damaged!

Although the edges are water and weather resistant, never use lots of water to clean the edges!

Never use high pressure water to clean the edges! Do not scratch the surface when cleaning the edges!

Disregard of the mentioned precaution may lead to a loss of safety!

7. Disposal

The light curtain should only be replaced if a similar door protection device is installed. Disposal should be done using the most up-to-date recycling technology according to local rules and laws. There are no harmful materials used in the design and manufacture of this light curtain. Traces of such dangerous materials could be used in the electronic components but not in quantities that are harmful to health.

device of the door mechanism. This ultimate safety function has to be provided by a fail safe force and kinetic energy limiter.

8. Technical Data

Supply voltage	10 ... 30 VDC
Supply current	typ. 60 mA (protected on site by a "slow-blow" 0.5 A fuse)
Output type	Semiconductor
Output switching current	max. 120 mA
Output polarity	Push and pull (PNP and NPN)
Output logic	NO and NC selectable
Response time	25 ... 120 ms
Operating range	0 ... 3 m (0 ... 10 feet)
Protection height	1800 mm (6 feet)
First beam above lower end of edge	20 mm (0.78")
Weight	0.3 kg
Sunlight	> 75'000 Lux
Protection class	IP 65 / Nema 4
Temperature range	-20 ... +65°C (-5 ... 150°F)
Cable length	5 m, detachable, color coded
Cable lifetime	20 million door movements (if correctly installed)
Diagnostics	LED's built into the connector

8.1. Certificate of Compliance

EU Standards EMV 89 / 336 / EC, changed 92 / 31 / EC

CSA Certificate no. No. 187273-1485166

Applicable Standards and Requirements
 EN 50081-1, -2 EMI Emission
 EN 50082-1, -2 EMI Immunity
 EN12015 EMI Emission for elevators and escalators
 EN12016 EMI Immunity for elevators and escalators
 CSA C22.2 No. 0 - M91
 CSA C22.2 No.14 - 95
 CSA C22.2 No. 94 - M91
 CSA - B44.1-96 / ASME - A17.5 -1996ed.
 UL 508, 16th ed.
 UL 50, 11th ed.

Quality All **ADAMS** products are developed and manufactured following generally accepted rules in industry and in compliance to a total quality management system certified to ISO 9001: 2000 by TÜV CERT.

9. Dimensions

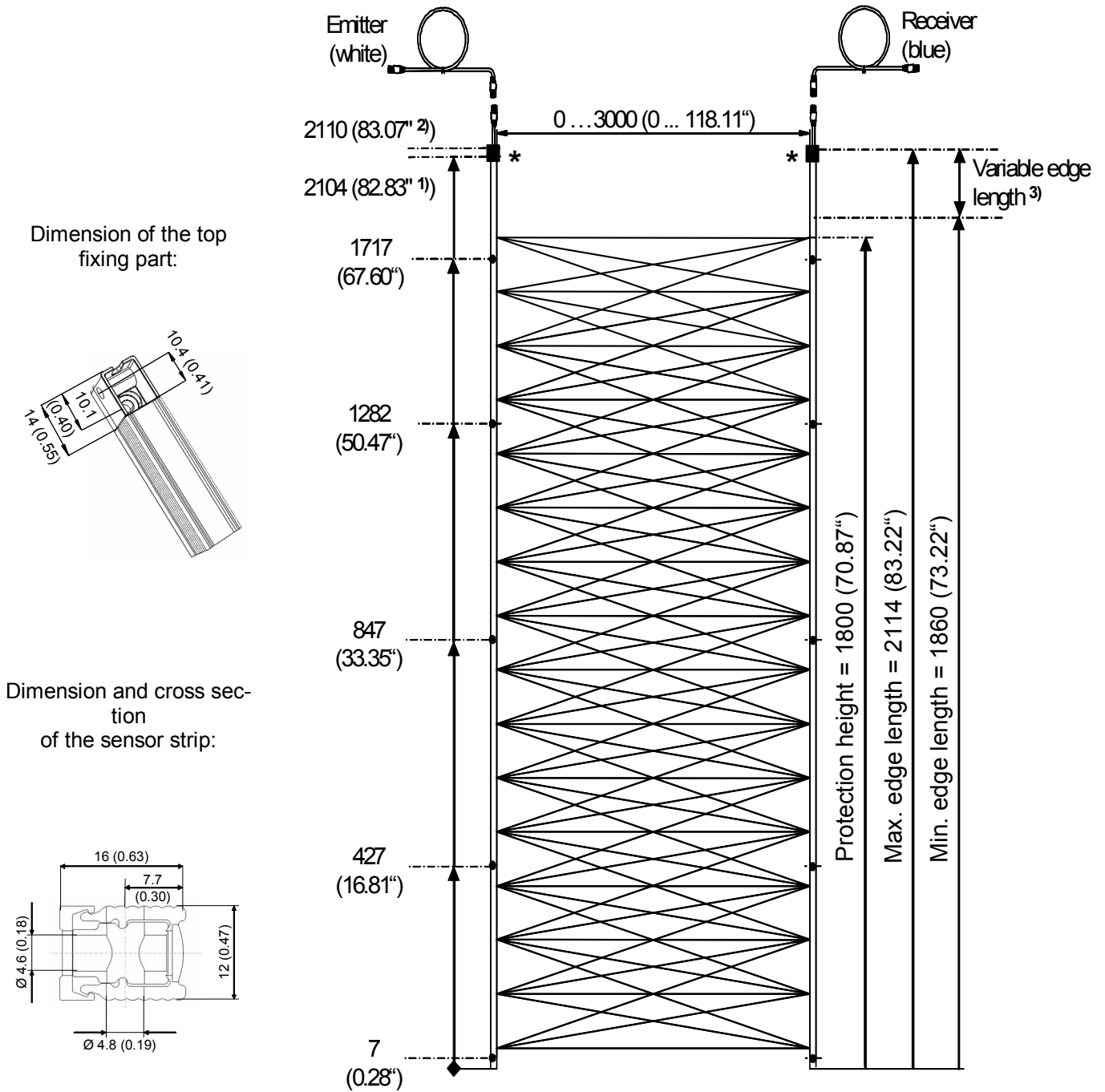

Dimension of the top fixing part:

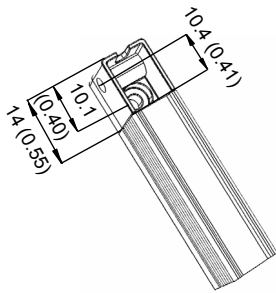

Dimension and cross section of the sensor strip:

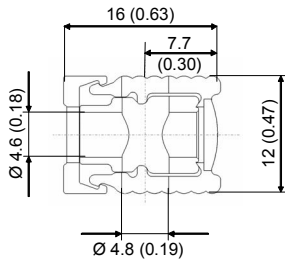

- 1) = Location for side mounting
- 2) = Location for front mounting
- 3) = Edge length can be adjusted individually between min. and max. edge length
- *) = Top fixing part
-) = Mountin holes

All dimensions in mm (Inches)

10. Part Numbers

10.1. Complete units

ADAMS Part No.	Description
A850G7EZ24V	Gatekeeper® EZ 7' with 159 beams for 24 VDC power supply, vision shield and mounting profiles included
A850G7EZ24LT	Gatekeeper® EZ 7' with 159 beams for 24 VDC power supply, vision shield and mounting profiles NOT included
A850G7EZ79	Gatekeeper® EZ 7' with 79 beams for 24 VDC power supply, vision shield and mounting profiles included
A850G7EZ79LT	Gatekeeper® EZ 7' with 79 beams for 24 VDC power supply, vision shield and mounting profiles NOT included

10.2. Spare parts and accessories

ADAMS Part No.	Description
A850GMP1	Universal power supply for 17 – 265 VDC or AC including relay output
A850G7EZ159T	Gatekeeper® EZ with 159 beams, transmitter
A850G7EZ159R	Gatekeeper® EZ with 159 beams, receiver
A850G7EZ79T	Gatekeeper® EZ with 79 beams, transmitter
A850G7EZ79R	Gatekeeper® EZ with 79 beams, receiver
A850G7EZ-RT1	Gatekeeper® EZ 16' transmitter cable (for A850G7EZ24V and A850G7EZ79)
A850G7EZ-RR1	Gatekeeper® EZ 16' receiver cable (for A850G7EZ24V and A850G7EZ79)
A850G7EZ-RR2	Gatekeeper® EZ 10' extension cable for transmitter and receiver (for A850G7EZ24V and A850G7EZ79)
A850G7-VS	Vision shield 7'
A850G7-MP	Mounting profile 7'
A850G7-SP	Spacer profile 7'
A850G7EZ-HW	Hardware bag (for A850G7EZ24V and A850G7EZ79)

