

### Hanger Assembly (330A Hydro/400A Traction)

(48" Side Opening)

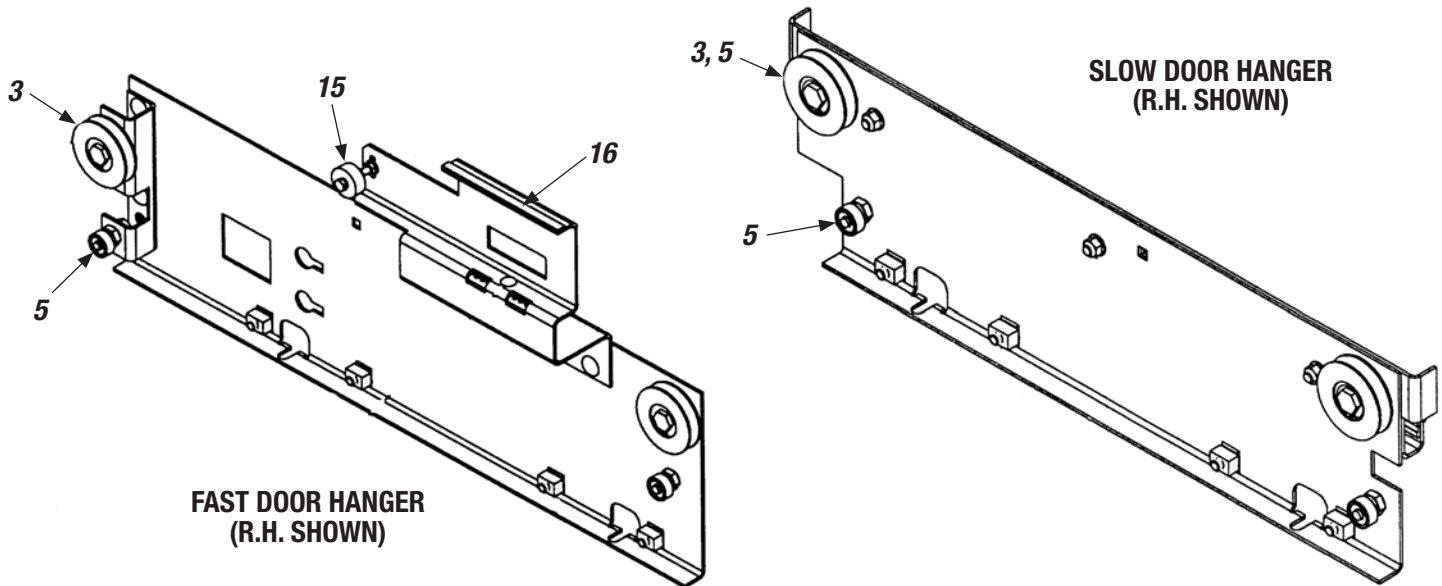

#### FAST DOOR HANGER

| Key No. | Part No.   | Description                 |
|---------|------------|-----------------------------|
| 3       | 576B535G98 | ROLLER ASSEMBLY             |
| 5       | 151B456G01 | UP THRUST ROLLER ASSEMBLY   |
| 15      | 5061A67G01 | GATE SWITCH ROLLER ASSEMBLY |
| 15.1    | 7431C95H15 | ROLLER                      |
| 16      | 1319B39H06 | MAGNETIC TAPE [1], [2]      |